

UOOK BMS BLE-COM (MODBUS-RTU) 簡易使用說明

MODBUS-RTU 訊息框:

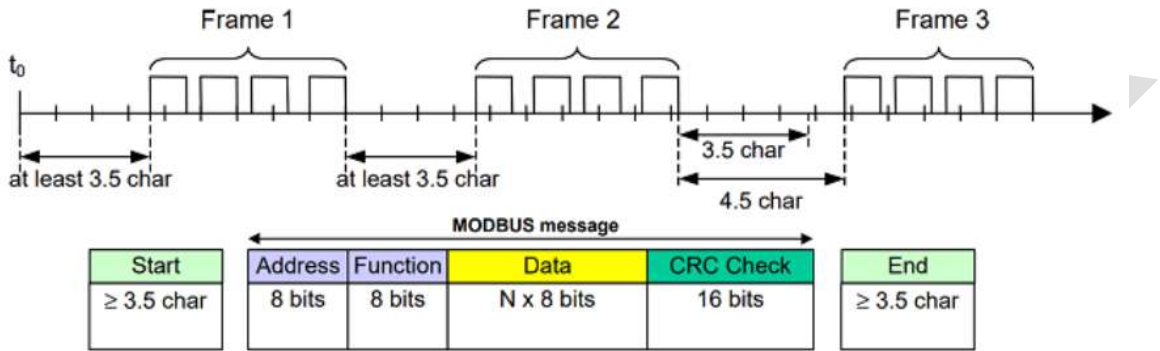

鮑率 (Baud Rate) : 9600 bps
 資料長度 (Data Bits) : 8 bits
 同位校驗 (Parity) : 無(N)
 停止位元 (Stop Bit) : 1bits

支持讀寫命令:

功能碼 (Function code)	說明	應用
0x03	讀取 Holding Registers	讀取電池資訊
0x06	寫入單一 Holding Register	寫入命令，控制電池開關或修改電池組態
0x10	寫入多個 Holding Registers	

UOOK BMS電池MODBUS Slave位址為03

主機使用功能碼0x03讀取Holding registers得到電池資訊，使用功能碼0x06或0x10寫入資料或控制命令，寫入命令前必需先寫入密碼解鎖，預設為12345678

連續(未中斷超過5秒)讀取Holding Registers，即表示PC連線中，顯示屏上會持續顯示PC字樣。

解鎖後未保持PC連線且30秒內無再寫入命令會自動上鎖，反之，維持解鎖狀態，寫入新命令後重新計算30秒。

參數表功能說明：

名稱	用途說明	行為
BMS Basic Information of BP-0,1,2,3	電池基本資訊,供主機端讀取	即時
BMS Temp. Information of BP-0,1,2,3	電池溫度資訊,供主機端讀取	即時
BMS Record Information of BP-0,1,2,3	電池記錄資訊,供主機端讀取	即時
BMS Cell Voltage Information of BP-0,1,2,3	電池壓資訊,供主機端讀取	即時
Holding Control Command Table	電池控制命令列表,可寫入0xF00執行命令	即時
BMS Parameter Configuration	電池組態參數,此為電池真實運行的參數設定值,專家模式使用,未開放於手機APP設定	需保存
Product Information Configuration	電池產品資訊,只用於主機識別電池用	需保存
Remote Connection Configuration	WIFI功能遠端連線設定	需保存
Battery Parameter Setting	電芯參數設定,使用者設定此區的參數再執行儲存至EEPROM來改變電池組態	需保存
Battery Standby Method	電池待機顯示時間,滿電再充電,空電再放電的規則設定	即時
BMS Password	電池密碼設定	即時
BMS Control	電池控制命令寫入及其它項目資訊	即時
Alarm Evant Table	警告號碼對應表	即時

行為說明：

寫入需保存的 Holding Registers 時,並不會立即影響電池功能,必需使用寫入 EEPROM 的命令將新的資料寫入 EEPROM 後經過重新開機自動重新設定後才會套用新的設定參數。

以下為更新電池參數的步驟

Step 1: 寫入電芯參數至 Holding registers(0x0E00~0E7F)

Step 2: 寫入控制命令 0x8214 至 Holding registers(0x0F00)

命令寫入後,控制器會自動比對組態是否改變,自動判斷是否重新開機。

附表 Register 定義:

Data Format:

- uint16: 16 bits unsigned integer.
- uint32: 32 bits unsigned integer.
- int16: 16 bits signed integer.
- bit16: 16 bits bit-alignment
- char192: 192 bits 12 characters

Holding Register Table:

Holding Register 0x0000~0x000F: BMS Basic Information of BP-0

Register address	Name	Format	Scale	Description / Unit	R/W
0x00	BP Version	uint8	--	Version code	R
	BP Number	uint8	--	0 ~ 255	R
0x01	Pack RSOC %	uint8	1	0 ~ 100 %	R
	Pack SOH %	uint8	1	0 ~ 100 %	R
0x02	Pack Capacity	uint16	0.1	0.0~6553.5 Ah	R
0x03	Pack Cycle	uint16	1	0 ~ 65535 Cycles	R
0x04	Pack Voltage	uint16	0.01	0.00 ~ 655.35 V	R
0x05	Pack Current	uint16	0.01	-327.68 A ~ 327.67 A	R
0x06	Max. Discharge Current	uint16	0.01	0.0 ~ 655.35 A	R
0x07	Max. Charge Current	uint16	0.01	0.0 ~ 655.35 A	R
0x08	Error Status H	uint16	--	Bit0: SCDL, Bit1: HWDF Bit2: PTO, Bit3: PTOS Bit4: SUV, Bit5: SOV Bit6: SOCC, Bit7: SOCD Bit8: SOT, Bit9: SOTF Bit10: CUDEP, Bit11: VREF Bit12: OTPF, Bit13: DRMF Bit14: IRMF, Bit15: TOSF	R
0x09	Error Status L	uint16	--	Bit0: CUV, Bit1: COV Bit2: OCC, Bit3: OCD1 Bit4: OCD2, Bit5: OCD3 Bit6: SCD, Bit7: UTC Bit8: UTD, Bit9: UTINT Bit10: OTC, Bit11: OTD Bit12: OTINT, Bit13: OTF Bit14: COVL, Bit15: OCDL	R
0x0A	Pack Status	uint16	--	Bit-0: Discharge ON Bit-1: Charge ON Bit-2: Discharge Enable Bit-3: Charge Enable Bit-4: Balancing ON Bit-5: Battery Idle Bit-6: BMS Full Bit-7: BMS Empty Bit-8: System OT Bit-9: Heat sink OT Bit-10: FAN OT Bit-11: ChgOverTime Bit-12: Battery Shutdown Bit-13: Vpk over Vstk Bit-14: Protect Alarm On Bit-15: System Error	R
0x0B	Balancing Status	uint16		16 Cells available (bit mapping)	R
0x0C	System Temp.	uint16	0.01	-327.68 ~ +327.67 °C	R
0x0D	Avg. Cell Voltage	int16	0.001	-32.768 ~ 32.767 V	R

0x0E	Stack Voltage	uint16	0.01	0.00 ~ 655.35 V	R
0x0F	Avg. Cell Temp.	int16	0.01	-327.68 ~ +327.67 °C	R

Holding Register 0x10~0x1F: BMS Temp. Information of BP-0

Index	Name	Format	Scale	Description / Unit	R/W
0x10~0x17	Cell Temp.	int16	0.01	Cells Temp. 1~8 -327.68 ~ +327.67 °C	R
0x18	FET Temp.	int16	0.01	-327.68 ~ +327.67 °C	R
0x19	IC Internal Temp.	int16	0.01	-327.68 ~ +327.67 °C	R
0x1A	System Temp.	int16	0.01	-327.68 ~ +327.67 °C	R
0x1B	Heatsink Temp.	int16	0.01	-327.68 ~ +327.67 °C	R

Holding Register 0x20~0x2F: BMS Record Information of BP-0

Register address	Name	Format	Scale	Description / Unit	R/W
0x20~0x21	Total Charge Power(Wh)	uint32	1	0~Ah	R
0x22~0x23	Total Discharge Power(Wh)	uint32	1	0~6553500Ah	R
0x24	Total Balance Time	uint16	1	0~65535Hours	R
0x25	Pack Discharge Cycle	uint16	1	0~65535 Cycles	R
0x26	Error Status H (Log)	bit16	--	Same define with Error Status H but bitwise with OR	R
0x27	Error Status L (Log)	bit16	--	Same define with Error Status L but bitwise with OR	R
0x28	SCDL times	uint8	1	0~255	R
	OCDL times	uint8	1	0~255	R
0x29	SOC max.	uint8	1	0~100%	R
	SOC min.	uint8	1	0~100%	R
0x2A	Cell Temp. max.	int8	1	-128~+127	R
	Cell Temp. min.	int8	1	-128~+127	R
0x2B	MOSFET Temp. max.	int8	1	-128~+127	R
	IC Temp. max.	int8	1	-128~+127	R
0x2C	Heatsink Temp. max.	int8	1	-128~+127	R
	System Temp. max.	int8	1	-128~+127	R
0x2D	Cell Voltage max.	uint8	1	0.0~25.5V	R
	Cell Voltage min.	uint8	1	0.0~25.5V	R
0x2E	Charge Current max.	uint8	1	0~255A	R
	Discharge Current max.	uint8	1	0~255A	R
0x2F	Pack Voltage max.	uint8	1	0~255V	R
	Stack Voltage min.	uint8	1	0~255V	R

Holding Register 0x30~0x3F: BMS Cell Voltage Information of BP-0

Register address	Name	Format	Scale	Description / Unit	R/W
0x30~0x3F	Pack-N Cells Voltage	int16	0.001	Cell-1 ~ 16 voltages -32.768 ~ 32.767 V	R

Holding Register 0x40~0x7F: BMS Information of BP-1

Register address	Name	Format	Scale	Description / Unit	R/W
0x40~0x4F	Basic Info	-	-	BMS Basic Information	R
0x50~0x5F	FET/ IC/ System/ Heatsink/ Cell Temp.	int16	0.01	BMS Temp. Information	R
0x60~0x6F	Record Information	-	-	BMS Record Information	R

0x70~0x7F	Pack-N Cells Voltage	int16	0.001	BMS Cell Volt Information	R
-----------	----------------------	-------	-------	---------------------------	---

Holding Register 0x80~0xBF: BMS Information of BP-2

Register address	Name	Format	Scale	Description / Unit	R/W
0x80~0x8F	Basic Info	-		BMS Basic Information	R
0x90~0x9F	FET/ IC/ System/ Heatsink/ Cell Temp.	int16	0.01	BMS Temp. Information	R
0xA0~0xAF	Record Information	-	-	BMS Record Information	R
0xB0~0xBF	Pack-N Cells Voltage	int16	0.001	BMS Cell Volt Information	R

Holding Register 0xC0~0xFF: BMS Information of BP-3

Register address	Name	Format	Scale	Description / Unit	R/W
0xC0~0xCF	Basic Info	-		BMS Basic Information	R
0xD0~0xDF	FET/ IC/ System/ Heatsink/ Cell Temp.	int16	0.01	BMS Temp. Information	R
0xE0~0xEF	Record Information	-	-	BMS Record Information	R
0xF0~0xFF	Pack-N Cells Voltage	int16	0.001	BMS Cell Volt Information	R

Holding Register 0xF00~0xFFF: BMS Control

Register address	Name	Format	Scale	Description / Unit	R/W
0xF00	Control Command	bit		Bit-0: EEPROM busy Bit-14: User Password PASS Bit-15: Factory Password PASS	R
		uint16		See Control Command Table	Wc
0xF01~0xFDF	Command Data	--		Data for Control command	R/Wr
0xFFE	Forward Data	uint16		Forward data	Wo
	Loop-Back Data	uint16		Loop-back from last BP	R
0xFFF	Last Linked BP ID	uint16		0 ~ 3	R

R/W type:

R: Read BMS data from this register address.

Wo: Write only data.

Wc: Write only command code.

Wr: Write the readback-able register data to linked BMS.

Holding Control Command Table:

Value	Description	Control Type
0x0000 ~ 0x0FFF	Write Modbus Holding register	User
0x1000 ~ 0x1FFF	Read Modbus Holding register	User
0x8100	Clear Log-2 Record regs (Erase EEPROM)	User
0x8102	Program All Record regs (from Record regs to EEPROM)	User
0x8213	Load Product Info. from EEPROM to Holding regs	User
0x8214	Program Battery Para. from Holding data to EEPROM	User
0x8215	Load Battery Para. from EEPROM to Holding regs	User
0x8216	Program Remote Connection Configuration	User
0x8217	Load Remote Connection Configuration	User
0x8218	Program Standby Power Method	User
0x8219	Load Standby Power Method	User
0x8220	Load MNC default Battery Para to Holding regs	User
0x8221	Load LFP default Battery Para to Holding regs	User
0x8310	Reset Battery Cell self dis-charge SOC rate calculation	User
0x8311	Reset SOH1 capacity calculation	User
0x9100	RTC time second increase 1	User
0x9101	RTC time second decrease 1	User
0x9102	RTC time minute increase 1	User
0x9103	RTC time minute decrease 1	User
0x9104	RTC time-hour increase 1	User
0x9105	RTC time-hour decrease 1	User
0x9106	RTC time-date increase 1	User
0x9107	RTC time-date decrease 1	User
0x9108	RTC time-month increase 1	User
0x9109	RTC time-month decrease 1	User
0x910a	RTC time-year increase 1	User
0x910b	RTC time-year decrease 1	User
0x910c	RTC time weekday increase 1	User
0x910d	RTC time weekday decrease 1	User
0x9110	Write RTC Time / Date, 4-word BCD data from command data to RTC, these data are Word[0][15:8] = Minute(0~59h), Word[0][7:0] = Second(0~59h), Word[1][7:0] = Hour(0~23h), Word[2][15:8] = Month(1~12h), Word[2][7:0] = Date(1~31h), Word[3][15:8] = Weekday(1~7h), Word[3][7:0] = Year(0~99h)	User
0xF000	System Power Off	User
0xF001	System Re-config	User
0xF002	System Shutdown	User
0xF003	System Restart	User
0xF100	BMS DSG Off (twice)	User
0xF101	BMS DSG On	User
0xF102	BMS CHG Off (twice)	User
0xF103	BMS CHG On	User
0xF104	BMS All Off (twice)	User
0xF105	BMS All On	User

0xF200	KEY LED On 30s	User
0xF201	KEY LED Off 30s	User
0xF300	Alarm Off	User
0xF301	Alarm On	User
0xFF00	Un-Lock BMS Control [Command Data] = Password	User
0xFF02	Lock BMS Control	User



Holding Register 0x0C00~0x0C7F: BMS Parameter Configuration

Register address	Name	Format	Scale	Description / Unit	R / W
0xC00	Pack pin Voltage Gain	uint16	1	0 ~ 65535	R/W
0xC01	Stack Voltage Gain	uint16	1	0 ~ 65535	R/W
0xC02	LD pin Voltage Gain	uint16	1	0 ~ 65535	R/W
0xC03	Voltage ADC Gain	int16	1	-32768 ~ 32767	R/W
0xC04	Vcell Offset	int16	--	-32768 ~ 32767	R/W
0xC05	V Divider Offset	int16	--	-32768 ~ 32767	R/W
0xC06	Columbo Count Offset	uint16	--	0 ~ 65535 samples	R/W
0xC07	Current Sense R	uint16	0.00001	0 ~ 0.65535 ohm	R/W
0xC08	Current Board Offset	int16	1	-32768 ~ 32767	R/W
0xC09	Reserved				
0xC0A	Cell-1 Temp. Offset	int8	1	For sensors 1 -128~127°C	R/W
	Cell-2 Temp. Offset	int8	1	For sensors 2 -128~127°C	R/W
0xC0B	Cell-3 Temp. Offset	int8	1	For sensors 3 -128~127°C	R/W
	Cell-4 Temp. Offset	int8	1	For sensors 4 -128~127°C	R/W
0xC0C	Cell-5 Temp. Offset	int8	1	For sensors 5 -128~127°C	R/W
	Cell-6 Temp. Offset	int8	1	For sensors 6 -128~127°C	R/W
0xC0D	Cell-7 Temp. Offset	int8	1	For sensors 7 -128~127°C	R/W
	Cell-8 Temp. Offset	int8	1	For sensors 8 -128~127°C	R/W
0xC0E	FET Temp. Offset	int8	1	For sensors 9 -128~127°C	R/W
	IC Temp. Offset	int8	1	For sensors 10 -128~127°C	R/W
0xC0F	System Temp. Offset	int8	1	For sensors 11 -128~127°C	R/W
	Heatsink Temp. Offset	int8	1	For sensors 12 -128~127°C	R/W
0xC10	SCD Limit	uint16	0.1	0.0 ~ 6553.5A	R/W
0xC11	SCD Delay Time	uint16	1	0 ~ 65535us	R/W
0xC12	SCD Recovery Time	uint8	1	0 ~ 255s	R/W
	SCD DecDelay Time	uint8	1	0 ~ 255s	
0xC13	SCDL Latch Limit	uint8	1	0 ~ 255 times	R/W
	SCDL Recovery Time	uint8	1	0 ~ 255s	
0xC14	SCDL Recovery Threshold	int16	1	-32768 ~ 32767mA	R/W
0xC15	OCD Limit	uint16	0.1	0.0 ~ 6553.5A	R/W
0xC16	OCD Delay Time	uint16	1	0 ~ 65535ms	R/W
0xC17	OCD Recovery Time	u8	1	0 ~ 255s	R/W
	OCD DecDelay Time	u8	1	0 ~ 255s	
0xC18	OCDL Latch Limit	u8	1	0 ~ 255 times	R/W
	OCDL Recovery Time	u8	1	0 ~ 255s	
0xC19	OCD Recovery Threshold	int16	1	-32768 ~ 32767mA	R/W
0xC1A	OCC Limit	uint16	0.1	0.0 ~ 6553.5A	R/W
0xC1B	OCC Delay Time	uint16	1	0 ~ 65535ms	R/W
0xC1C	OCC Recovery Threshold	int16	1	-32768~32767mA	R/W
0xC1D	OTC Threshold	int8	1	-40 ~ 120°C	R/W
	OTC Recovery	int8	1	-40 ~ 120°C	
0xC1E	OTC Delay	uint8	1	0 ~ 255s	R/W
	OTD Delay	uint8	1	0 ~ 255s	
0xC1F	OTD Threshold	int8	1	-40 ~ 120°C	R/W
	OTD Recovery	int8	1	-40 ~ 120°C	
0xC20	UTC Threshold	int8	1	-40 ~ 120°C	R/W
	UTC Recovery	int8	1	-40 ~ 120°C	
0xC21	UTC Delay	uint8	1	0 ~ 255s	R/W
	UTD Delay	uint8	1	0 ~ 255s	
0xC22	UTD Threshold	int8	1	-40 ~ 120°C	R/W
	UTD Recovery	int8	1	-40 ~ 120°C	
0xC23	OTF Threshold	int8	1	-40 ~ 120°C	R/W
	OTF Recovery	int8	1	-40 ~ 120°C	

0xC24	OTINT Threshold	int8	1	-40 ~ 120°C	R/W
	OTINT Recovery	int8	1	-40 ~ 120°C	
0xC25	OTF Delay	uint8	1	0 ~ 255s	R/W
	OTINT Delay	uint8	1	0 ~ 255s	
0xC26	OTS Threshold	int8	1	-40 ~ 120°C	R/W
	OTS Recovery	int8	1	-40 ~ 120°C	
0xC27	OTH Threshold	int8	1	-40 ~ 120°C	R/W
	OTH Recovery	int8	1	-40 ~ 120°C	
0xC28	OTS Delay	uint8	1	0 ~ 255s	R/W
	OTH Delay	uint8	1	0 ~ 255s	
0xC29	Recovery Time	uint8	1	0 ~ 255s	R/W
	Pre-charge Time	uint8	1	0 ~ 255s	
0xC2A	SOV Limit	uint16	0.0001	0 ~ 6.5535 V	R/W
0xC2B	COV Limit	uint16	0.0001	0 ~ 6.5535 V	R/W
0xC2C	Cell CHG Voltage	uint16	0.0001	0 ~ 6.5535 V	R/W
0xC2D	COV Reset	uint16	0.0001	0 ~ 6.5535 V	R/W
0xC2E	CUV Reset	uint16	0.0001	0 ~ 6.5535 V	R/W
0xC2F	Cell DSG Voltage	uint16	0.0001	0 ~ 6.5535 V	R/W
0xC30	CUV Limit	uint16	0.0001	0 ~ 6.5535 V	R/W
0xC31	SUV Limit	uint16	0.0001	0 ~ 6.5535 V	R/W
0xC32	Body Diode Threshold	int16	1	-32768~32767mA	R/W
0xC33	Protection Enable 0	bit16	--	Bit0: SCDL, Bit1: HWDF Bit2: PTO, Bit3: PTOS Bit4: SUV, Bit5: SOV Bit6: SOCC, Bit7: SOCD Bit8: SOT, Bit9: SOTF Bit10: CUDEP, Bit11: VREF Bit12: OTPF, Bit13: DRMF Bit14: IRMF, Bit15: TOSF	R/W
0xC34	Protection Enable 1	bit16	--	Bit0: CUV, Bit1: COV Bit2: OCC, Bit3: OCD1 Bit4: OCD2, Bit5: OCD3 Bit6: SCD, Bit7: UTC Bit8: UTD, Bit9: UTINT Bit10: OTC, Bit11: OTD Bit12: OTINT, Bit13: OTF Bit14: COVL, Bit15: OCDL	R/W
0xC35	Function Enable	bit16	--	Bit0: SCDL CURR RECOVERY Bit-1: OCDL CURR RECOVERY Bit-2: PF_DPSLP Bit-3: PF_REGS Bit-4: PF_FETS Bit-5: Auto Balance	R/W
0xC36	Cell Connect	bit16	--	Bit-0: Cell-1 connected. Bit-1: Cell-2 connected. Bit-2: Cell-3 connected. Bit-3: Cell-4 connected. Bit-4: Cell-5 connected. Bit-5: Cell-6 connected. Bit-6: Cell-7 connected. Bit-7: Cell-8 connected. Bit-8: Cell-9 connected. Bit-9: Cell-10 connected. Bit-10: Cell-11 connected. Bit-11: Cell-12 connected. Bit-12: Cell-13 connected. Bit-13: Cell-14 connected. Bit-14: Cell-15 connected.	R/W

				Bit-15: Cell-16 connected.	
0xC37	Thermal Sensor Connect	bit16		Bit-0: TS-1 Connected Bit-1: TS-2 Connected Bit-2: TS-3 Connected Bit-3: TS-4 Connected Bit-4: TS-5 Connected Bit-5: TS-6 Connected Bit-6: TS-7 Connected Bit-7: TS-8 Connected Bit-8: TS-9 Connected Bit-9: TS-10 Connected Bit-10: TS-11 Connected Bit-11: TS-12 Connected Bit [15:12]: Cell Type	R/W
0xC38	OCD1 Limit	uint16	0.1	0.0 ~ 6553.5A	R/W
0xC39	OCD1 Delay Time	uint16	1	0 ~ 65535ms	R/W
0xC3A	OCD2 Limit	uint16	0.1	0.0 ~ 6553.5A	R/W
0xC3B	OCD2 Delay Time	uint16	1	0 ~ 65535s	R/W
0xC3C	Cell Number	uint16	1	4~16	R/W
0xC7F	Reserved for CRC16			Calculate from 0xC00 ~ 0xC7F	R

Holding Register 0x0C80~0x0CFF: Reserved

Register address	Name	Format	Scale	Description / Unit	R / W
0xCFF	Reserved for CRC16			Calculate from 0xC80 ~ 0CFF	R

Holding Register 0x0D00~0x0D7F: Product Information Configuration

Register address	Name	Format	Scale	Description / Unit	R / W
0xD00~0xD07	BMS PSN code	char128		16 characters	R/W
0xD08~0xD0F	BMS F/W Version	char128		16 characters	R/W
0xD10~0xD1F	BMS Model Name	char256		32 characters	R/W
0xD20~0xD2F	BMS Manufacture Info.	char256		32 characters	R/W
0xD30~0xD3F	Product Name	char256		32 characters	R/W
0xD40~0xD4F	Product Manufacture Info.	char256		32 characters	R/W
0xD50~0xD5F	Product Serial Number	char64		32 characters	R/W
0xD60~0xD6F	Battery Cell Model Name	char256		32 characters	R/W
0xD70~0xD7E	Reserved	char64			
0xD7F	Reserved for CRC16			Calculate from 0xD00 ~ 0xD7F	R

Holding Register 0x0D80~0x0DFF: Remote Connection Configuration

Register address	Name	Format	Scale	Description / Unit	R / W
0xD80~0xD87	WIFI AP name (prefix)	char128		16 characters	R/W
0xD88~0xD8F	BLE name (prefix)	char128		16 characters	R/W
0xD90~0xD9F	NTP server	char512		64 characters	R/W
0xDB0~0xDCf	MQTT connect server	char512		64 characters	R/W
0xDD0~0xDD7	MQTT device (prefix)	char128		16 characters	R/W

0xDD8~0xDDB	MQTT sub	char64		8 characters	R/W
0xDDC~0xDDF	MQTT pub	char64		8 characters	R/W
0xDFF	Reserved for CRC16			Calculate from 0xF80 ~ 0xDFF	R



Holding Register 0x0E00~0x0E7F: Battery Parameter Setting

Register address	Name	Format	Scale	Description / Unit	R / W
0xE00	Nominal Capacity	uint16	0.1	0.0 ~ 6553.5Ah	R/W
0xE01	Charge Capability	uint16	0.1	0.0 ~ 6553.5C	R/W
0xE02	Discharge Capability	uint16	0.1	0.0 ~ 6553.5C	R/W
0xE03	Pulse Discharge Capability	uint16	0.1	0.0 ~ 6553.5C	R/W
0xE04	Cell Internal R	uint16	0.01	0 ~ 0.65535mohm	R/W
0xE05	Fixed Capacity Ratio	uint16	0.0001	0.0000 ~ 1.0000	R/W
0xE06	Charge Efficiency	uint16	0.0001	0.0000 ~ 1.0000	R/W
0xE07	Degrade To Cycles	uint16	--	20% @ 6000 cycles	R/W
0xE08	Maximal Charge Time	uint16	1	0 ~ 65535s	R/W
0xE09	Typical Voltage	uint16	0.001	0 ~ 65.355V	R/W
0xE0A	Charge Cut-Off Voltage	uint16	0.001	0 ~ 65.355V	R/W
0xE0B	Discharge Cut-Off Voltage	uint16	0.001	0 ~ 65.355V	R/W
0xE0C	Charge Temp. Min.	int8	1	-40 ~ 120°C	R/W
	Charge Temp. Max.	int8	1	-40 ~ 120°C	R/W
0xE0D	Discharge Temp. Min.	int8	1	-40 ~ 120°C	R/W
	Discharge Temp. Max.	int8	1	-40 ~ 120°C	R/W
0xE0E	Battery Idle +SOC	uint8	0.1	0.0 ~ 25.5%	R/W
	Battery Empty SOC	uint8	0.1	0.0 ~ 25.5%	
0xE0F	Battery Max. Cont. CHG Time	uint16	1	0 ~ 65535s	R/W
0xE10	Low Power Current	uint16	1	0 ~ 65535 mA	R/W
0xE11	System Error Count Max.	uint16	1	0 ~ 65535 times	R/W
0xE20	OCV Voltage 0%	int16	0.001	0 ~ 32.768 V	R/W
0xE21	OCV Voltage 5%	int16	0.001	0 ~ 32.768 V	R/W
0xE22	OCV Voltage 10%	int16	0.001	0 ~ 32.768 V	R/W
0xE23	OCV Voltage 15%	int16	0.001	0 ~ 32.768 V	R/W
0xE24	OCV Voltage 20%	int16	0.001	0 ~ 32.768 V	R/W
0xE25	OCV Voltage 25%	int16	0.001	0 ~ 32.768 V	R/W
0xE26	OCV Voltage 30%	int16	0.001	0 ~ 32.768 V	R/W
0xE27	OCV Voltage 35%	int16	0.001	0 ~ 32.768 V	R/W
0xE28	OCV Voltage 40%	int16	0.001	0 ~ 32.768 V	R/W
0xE29	OCV Voltage 45%	int16	0.001	0 ~ 32.768 V	R/W
0xE2A	OCV Voltage 50%	int16	0.001	0 ~ 32.768 V	R/W
0xE2B	OCV Voltage 55%	int16	0.001	0 ~ 32.768 V	R/W
0xE2C	OCV Voltage 60%	int16	0.001	0 ~ 32.768 V	R/W
0xE2D	OCV Voltage 65%	int16	0.001	0 ~ 32.768 V	R/W
0xE2E	OCV Voltage 70%	int16	0.001	0 ~ 32.768 V	R/W
0xE2F	OCV Voltage 75%	int16	0.001	0 ~ 32.768 V	R/W
0xE30	OCV Voltage 80%	int16	0.001	0 ~ 32.768 V	R/W
0xE31	OCV Voltage 85%	int16	0.001	0 ~ 32.768 V	R/W
0xE32	OCV Voltage 90%	int16	0.001	0 ~ 32.768 V	R/W
0xE33	OCV Voltage 95%	int16	0.001	0 ~ 32.768 V	R/W
0xE34	OCV Voltage 100%	int16	0.001	0 ~ 32.768 V	R/W
0xE35	Cell SOV Limit	uint16	0.001	0 ~ 32.768 V	R/W
0xE36	Cell CHG Voltage	uint16	0.001	0 ~ 32.768 V	R/W
0xE37	Cell COV Reset	uint16	0.001	0 ~ 32.768 V	R/W
0xE38	Cell CUV Reset	uint16	0.001	0 ~ 32.768 V	R/W
0xE39	Cell DSG Voltage	uint16	0.001	0 ~ 32.768 V	R/W
0xE3A	Cell SUV Limit	uint16	0.001	0 ~ 32.768 V	R/W
0xE40	Balance diff. cell volt.	uint16	0.001	0 ~ 32.768 V	R/W

0xE41	Balance min. cell volt.	uint16	0.001	0 ~ 32.768 V	R/W
0xE42	Balance high cell volt.	uint16	0.001	0 ~ 32.768 V	R/W
0xE43	Balance low cell volt.	uint16	0.001	0 ~ 32.768 V	R/W
0xE44	Balance CHG min. SOC	uint8	1	0 ~ 100 %	R/W
0xE45	Balance Idle Current	uint16	1	0 ~ 65535mA	R/W
0xE46	Balance Idle Delay	uint16	1	0 ~ 65535s	R/W
0xE47	Balance Cell DSG R	uint16	0.1	0.0 ~ 25.5ohm	R/W
0xE48	Balance Cell CHG Current	uint16	1	0~65535mA	R/W
0xE49	Balance BP DSG Power	uint16	0.01	0 ~ 655.35W	R/W
0xE4A	Balance BP Max. Time	uint16	1	0 ~ 65535s	R/W
0xE4B	Balance Max. Time	uint16	1	0 ~ 65535s	R/W
0xE4C	Balance Min. Time	uint16	1	0 ~ 65535s	R/W
0xE4D	Balance Stop Pack Cycles	uint16	1	0 ~ 65535 cycles	R/W
0xE50	Cell-1 Wire Conn. R	uint16	0.01	0 ~ 655.35 m-ohm	R/W
0xE51	Cell-2 Wire Conn. R	uint16	0.01	0 ~ 655.35 m-ohm	R/W
0xE52	Cell-3 Wire Conn. R	uint16	0.01	0 ~ 655.35 m-ohm	R/W
0xE53	Cell-4 Wire Conn. R	uint16	0.01	0 ~ 655.35 m-ohm	R/W
0xE54	Cell-5 Wire Conn. R	uint16	0.01	0 ~ 655.35 m-ohm	R/W
0xE55	Cell-6 Wire Conn. R	uint16	0.01	0 ~ 655.35 m-ohm	R/W
0xE56	Cell-7 Wire Conn. R	uint16	0.01	0 ~ 655.35 m-ohm	R/W
0xE57	Cell-8 Wire Conn. R	uint16	0.01	0 ~ 655.35 m-ohm	R/W
0xE58	Cell-9 Wire Conn. R	uint16	0.01	0 ~ 655.35 m-ohm	R/W
0xE59	Cell-10 Wire Conn. R	uint16	0.01	0 ~ 655.35 m-ohm	R/W
0xE5A	Cell-11 Wire Conn. R	uint16	0.01	0 ~ 655.35 m-ohm	R/W
0xE5B	Cell-12 Wire Conn. R	uint16	0.01	0 ~ 655.35 m-ohm	R/W
0xE5C	Cell-13 Wire Conn. R	uint16	0.01	0 ~ 655.35 m-ohm	R/W
0xE5D	Cell-14 Wire Conn. R	uint16	0.01	0 ~ 655.35 m-ohm	R/W
0xE5E	Cell-15 Wire Conn. R	uint16	0.01	0 ~ 655.35 m-ohm	R/W
0xE5F	Cell-16 Wire Conn. R	uint16	0.01	0 ~ 655.35 m-ohm	R/W
0xE60	Int. R rate at SOC 0%	uint16	0.001	0~65.535	R/W
0xE61	Int. R rate at SOC 1%	uint16	0.001	0~65.535	R/W
0xE62	Int. R rate at SOC 2%	uint16	0.001	0~65.535	R/W
0xE63	Int. R rate at SOC 3%	uint16	0.001	0~65.535	R/W
0xE64	Int. R rate at SOC 4%	uint16	0.001	0~65.535	R/W
0xE65	Int. R rate at SOC 5%	uint16	0.001	0~65.535	R/W
0xE66	Int. R rate at SOC 7%	uint16	0.001	0~65.535	R/W
0xE67	Int. R rate at SOC 9%	uint16	0.001	0~65.535	R/W
0xE68	Int. R rate at SOC 11%	uint16	0.001	0~65.535	R/W
0xE69	Int. R rate at SOC 13%	uint16	0.001	0~65.535	R/W
0xE6A	Int. R rate at SOC 15%	uint16	0.001	0~65.535	R/W
0xE6B	Int. R rate at SOC 20%	uint16	0.001	0~65.535	R/W
0xE6C	Int. R rate at SOC 40%	uint16	0.001	0~65.535	R/W
0xE6D	Int. R rate at SOC 60%	uint16	0.001	0~65.535	R/W
0xE6E	Int. R rate at SOC 80%	uint16	0.001	0~65.535	R/W
0xE6F	Int. R rate at SOC 100%	uint16	0.001	0~65.535	R/W
0xE7F	Reserved for CRC16			Calculate from 0xE00 ~ 0xE7F	R

Holding Register 0x0E80~0x0E8F: Battery Standby Method

Register address	Name	Format	Scale	Description / Unit	R / W
------------------	------	--------	-------	--------------------	-------

0xE80	Green Power Mode	uint16	1	0: Disable: Level 1 ~ 65535	R/W
0xE81	Battery Full SOC	uint16	1	0 ~ 100%	R/W
0xE82	Battery Empty SOC	uint16	1	0 ~ 100%	R/W
0xE83	Power Return-On SoC	uint16	1	0 ~ 100%	R/W
0xE84	BP Connect Mode	uint16	1	0 : Single 1 : Serial 2 : Parallel	R/W
0xE85	Alarm Mode	uint16	1	0 : disable Level 1 ~ 9	R/W
0xE86	Display Standby Time	uint16	1	0 : always On 1 ~ 65535 second	R/W
0xE8F	Reserved for CRC16			Calculate from 0xE80 ~ 0xEFF	R

Holding Register 0xE90~0xE9F: BMS Password

Register address	Name	Format	Scale	Description / Unit	R / W
0xE90~0xE93	Factory's Password	char64		8 characters, factory configuration used by supervisor	R/W
0xE94~0xE97	Agent's Password	char64		8 characters, iOS/Android App used by Agent	R/W
0xE98~0xE9B	User's Password	char64		8 characters, OS/Android App used by user	R/W
0xE9F	Reserved for CRC16			Calculate from 0xE90 ~ 0xE9F	R

Holding Register 0xF00~0xFFF: BMS Control

Register address	Name	Format	Scale	Description / Unit	R/W
0xF00	Control Command	uint16		See Control Command Table The register data will be clear to 0 after command be executed	R/Wc
0xF01~0xFDF	Command Data	--		Data for Control command	R/Wr
0xFE0	Cell-1 Int. Resistance	uint16	0.01	0 ~ 655.35 m-ohm	R
0xFE1	Cell-2 Int. Resistance	uint16	0.01	0 ~ 655.35 m-ohm	R
0xFE2	Cell-3 Int. Resistance	uint16	0.01	0 ~ 655.35 m-ohm	R
0xFE3	Cell-4 Int. Resistance	uint16	0.01	0 ~ 655.35 m-ohm	R
0xFE4	Cell-5 Int. Resistance	uint16	0.01	0 ~ 655.35 m-ohm	R
0xFE5	Cell-6 Int. Resistance	uint16	0.01	0 ~ 655.35 m-ohm	R
0xFE6	Cell-7 Int. Resistance	uint16	0.01	0 ~ 655.35 m-ohm	R
0xFE7	Cell-8 Int. Resistance	uint16	0.01	0 ~ 655.35 m-ohm	R
0xFE8	Cell-9 Int. Resistance	uint16	0.01	0 ~ 655.35 m-ohm	R
0xFE9	Cell-10 Int. Resistance	uint16	0.01	0 ~ 655.35 m-ohm	R
0xFEa	Cell-11 Int. Resistance	uint16	0.01	0 ~ 655.35 m-ohm	R
0xFEb	Cell-1 2Int. Resistance	uint16	0.01	0 ~ 655.35 m-ohm	R
0xFEc	Cell-13 Int. Resistance	uint16	0.01	0 ~ 655.35 m-ohm	R
0xFEd	Cell-14 Int. Resistance	uint16	0.01	0 ~ 655.35 m-ohm	R
0xFEE	Cell-15 Int. Resistance	uint16	0.01	0 ~ 655.35 m-ohm	R
0xFEf	Cell-16 Int. Resistance	uint16	0.01	0 ~ 655.35 m-ohm	R
0xFF0	Forward Data	uint16		Forward data	Wo

	Loop-Back Data	uint16		Loop-back from last BP	R
0xFF1	SOH1 Capacity	uint8	1	0 ~ 255%	R
	SOH2 Cycle	uint8	1	0 ~ 255%	R
0xFF2	SOH3 Internal-R	uint8	1	0 ~ 255%	R
	SOH4 Diff. Cell-V	uint8	1	0 ~ 255%	R
0xFF3	Alarm event number	uint16	1	0 ~ 65535 See Alarm Event Table	R
0xFF4	Cell Self-Dis Rate	uint16	0.0001	0.0000 ~ 6.5535 SOC/24hour	R
0xFF5~0xFF8	Reserved				
0xFF9	WIFI RSSI	int16	1	WIFI Antenna power RSSI -32768~32767 dbm	R
0xFFA	Time: Second	BCD8		Second of Time	R
	Time: Minute	BCD8		Minute of Time	R
0xFFB	Time: Hour	BCD8		Hour of Time	R
0xFFC	Date: Date	BCD8		Date of Date	R
	Date: Month	BCD8		Month of Date	R
0xFFD	Date: Year	BCD8		Year of Date	R
	Date: Weekday	BCD8		Week day of Date	R
0xFFE	System Status	bit16		Bit0: PC linkd Bit1: UP linked Bit2: DN linked Bit3: User Password PASS Bit4: Factory Password PASS Bit5: System busy Bit6: Beep Alarm Enable Bit7: Reserved Bit8: WIFI connected Bit9: MQTT connected Bit10: BLE connected Bit11: TIME updated Bit12: Ethernet IP got Bit13: Beep Alarm Enable	R
0xFFFF	Last Linked BP ID	uint16		0 ~ 3	R

Alarm Event Table

Event No.	Event Name	Alarm description
0	NO EVENT	No Alarm event occur
1	BAT EMPTY	Battery power going to empty
2	HIGH TEMP	One of thermal temp. too high
3	URGENT TEMP	Thermal temp increase too urgent (> 0.1°C/second, continue times > 10 times)